

# HYDROPOMPE 100

DUAL-OPERATOR, FOOT-OPERATED PUMP FOR VERY DEEP BOREHOLES AND WELLS



## ➔ The “deep well” pump

*A reliable technology - hydraulic transmission - proven on 50,000 water points since 1975.*

① The HPV 100 pump totally satisfies VLOM (Village Level Operation and Maintenance) criteria.

② Delivered with its extraction system, the HPV 100 pump is easy to install and maintain. It can be assembled and disassembled by hand by any technician.

③ The foot-operated pump can be driven by two people at the same time, delivering much more energy than with hand operation, making it possible to exploit deep boreholes at satisfactory flow rates.

④ All wearing parts are at ground level and very accessible for replacement using a single tool delivered with the pump.

⑤ The average maintenance cost is unrivalled today: 15 to 30 euros per year. Wearing parts are available in all stores of the VERGNET HYDRO network.

⑥ The HPV 100 pump is totally corrosion resistant thanks to the use of rust-proof materials.

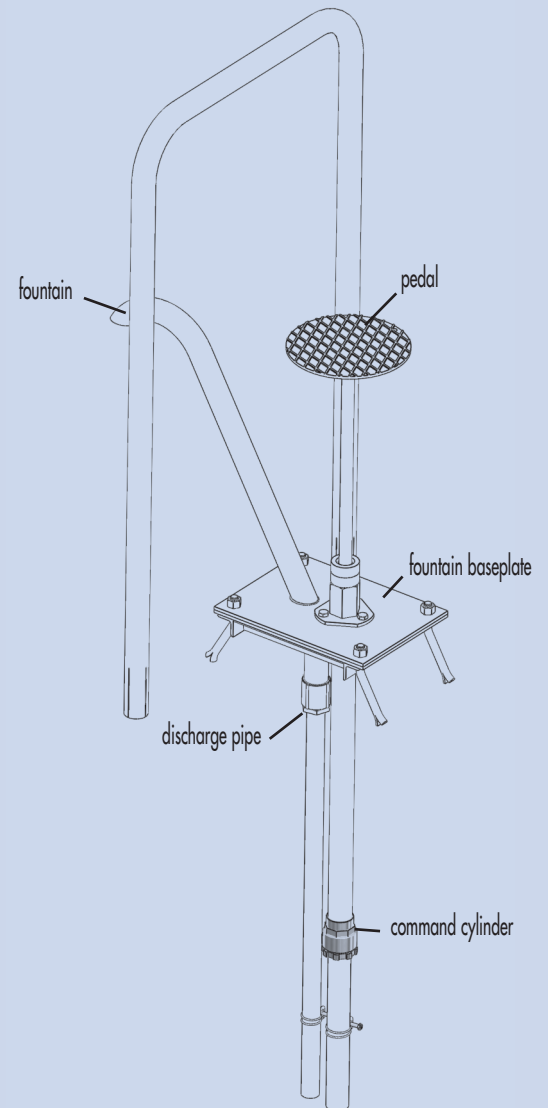

Several pumps on the same well

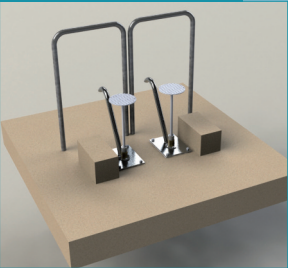

A vertical borehole is not essential

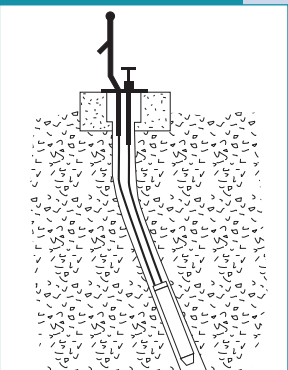

Simple extraction system

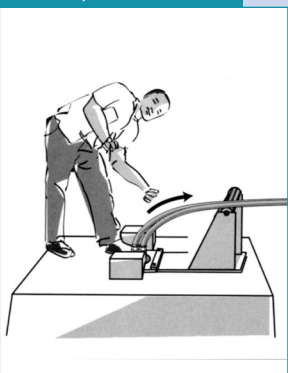

\*[Village Level Operation and Maintenance]

# HYDROPOMPE 100

DUAL-OPERATOR, FOOT-OPERATED PUMP FOR VERY DEEP BOREHOLES AND WELLS

## Operation

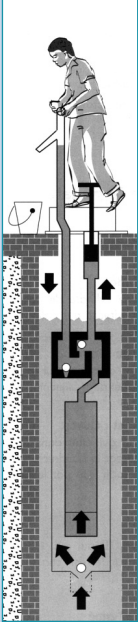

### Suction:

As the pedal rises the bladder retracts sucking water into the stainless steel pump body.

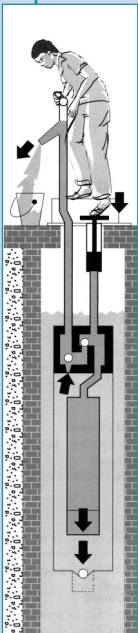

### Discharge:

As the pedal is pressed down the bladder distends, driving water to the surface.

## Technical specifications

### Pump type:

Hydraulic transmission, foot-operated, multi-operator

### Maximum operating depth:

40 to 120 metres dynamic level  
130 metres installation level

### Minimum well diameter:

For 1 pump: 5"\*  
For 2 pumps: 5" → 6"

### Fountain assembly:

galvanised steel  
Weight: 14 kg

### Command cylinder:

stainless steel  
Inner diameter: 30 mm  
Wall thickness: 6 mm  
Cylinder length: 610 mm

### Command rod (stainless steel, driven by the pedal):

Length: 660 mm  
Diameter: 22 mm

### Pump body:

stainless steel  
Overall length: 2320 mm  
Outer diameter: 90 mm  
Weight: 15 kg

### Bladder:

Natural length: 1590 mm  
Very severe quality control testing enables a 3 year guarantee and a 15 year working life expectancy

### Pipes:

High-density polyethylene

#### Transmission pipe:

Outer diameter: 40 mm  
Inner diameter: 21.2 mm

#### Discharge pipe:

Outer diameter: 32 mm  
Inner diameter: 26.4 mm

Pipe weight: 1.175 kg per metre of transmission pipe and discharge pipe

### Valves:

Ball valves (synthetic materials or stainless steel).

#### Three valve functions:

*Suction:* at the bottom of the pump ;  
*Discharge and repriming:* housed in the valve box located on the upper part of the pump body.

### Strainer:

The HPV 100 pump body is delivered with a standard polyethylene strainer  
The fountain is mounted on a fixing frame using brass nuts.

## Performance

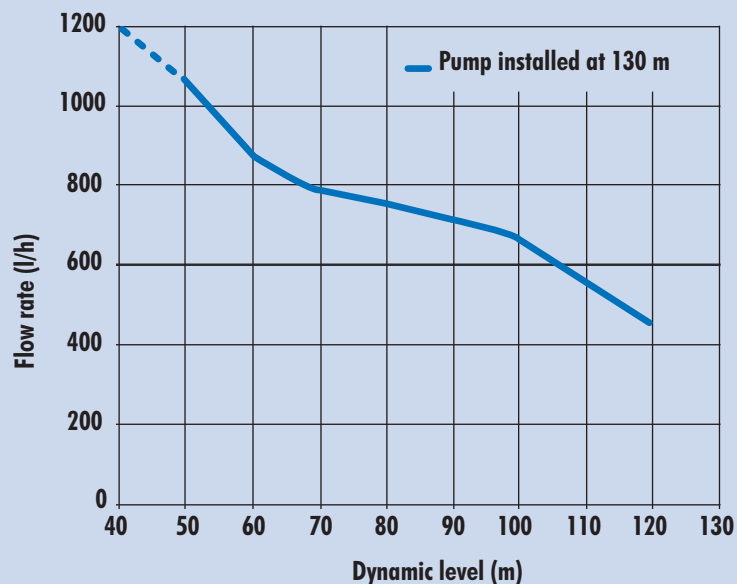

\* Consult for 4"

Certification no.BV-OLN 494018  
12/04/1994 - Bureau Véritas